

User Manual

(Translation of the original instructions)



Electronic Vibration Monitoring Unit

ESW[®]-Compact_II (hol600)

date: 13.12.2022

technical modification possible

holthausen elektronik GmbH is certified according to DIN EN ISO 9001:2015.



Table of contents

1. Generally basical safety-indications	page 4
2. Packing and the transport	page 4
3. Application.....	page 5
4. Measurement principle	page 5
5. Grounding concept.....	page 6
6. Mounting of the vibration control unit	page 7
7. Opening and closing of the vibration control unit..	page 8
8. Maintenance.....	page 8
9. Display- and operation- elements.....	page 9
10. Measurement range switching	page 10
11. Analog output	page 10
12. Analog output settings.....	page 11
13. Adjustment of the limiting values.....	page 11
14. Example for adjustment of the limit value.....	page 12
15. Self test	page 13
16. Housing size.....	page 14
17. Cable connection draft	page 15
Technical data.....	appendix

Important information

These operation instructions are to be read through completely and carefully heeded before starting the device. Failure to heed or adhere can result in claims on manufacturer's liability becoming null and void for damages ensuing there from.

Manual action of any manner on the device – with the exception of proper procedures and those described in these operation instructions – lead to forfeit of guarantee and exclusion from liability.

The device is solely intended for the usage as described below. It is particularly not intended for the direct or indirect protection of persons.

holthausen elektronik GmbH assumes no liability whatsoever as regards suitability for some specific purpose.

If any question should remain open, please never hesitate to contact us.

holthausen elektronik GmbH

Wevelinghoven 38, 41334 Nettetal

Phone: +49 (0) 21 53 - 40 08, Fax: +49 (0) 21 53 - 8 99 94

Mail: info@holthausen-elektronik.de

1. Generally basical safety-indications

Don't use this device as the only invigilator, if a malfunctioning of ESW[®]-Compact_II could lead to damages on goods or Persons.

To obtain the desired result be sure, that the device with its technical data fits to the bulk of the object you want to supervise.

The sensor is sensitive to shock. A downfall out lower height to a hard substratum can destroy the sensor.

The assembling place and the execution of the assembling of the sensor determine decisively the quality of the sensor signal. The assembling may only happen through qualified and instructed persons.

The electrical hook up is to be done by instructed persons. A mistake by the connection can entail to faulty functions, outfall or ruination of the sensor and electronics.

The ESW[®]-Compact_II should not be used on machines with a very energetic high-frequency solid-borne. Through resonance apparitions in the sensor, the device can indicate a much too great or too small value.

Powerful noise sources for instance inverters, in direct closeness of the sensor, electronics or cabling, can result in faulty behaving of the apparatus.

Potential differences and balance currents in the mass guidance can result in faulty behaving too.

The connection cable is resistant against many but not every type of chemicals. Through a damaged cable chemicals could get inside the unit and destroy the electronic. Then the unit would loose their function. Therefore the conditions from the mounting surrounding must be checked. Then the cover material from the cable have to be proofed if it resists these requirements. You can get an overview from the chemical resistance of the cover material from us.

2. Packing and the transport

Note:

- The sensor is sensitive to shock. A downfall out lower height to an hard substratum can destroy the sensor.
- Avoid to kink or tie a knot in the cable.
- Keep the electronic in a dry place.
- In case of a downfall or heckling or squeezing, could the casing or the operation elements or the board get defects.

With adequate warning-labels and through a qualified packaging and storage, you can protect the sensor and electronics at carriage against influences from outside.

3. Application

The ESW[®]-Compact_II will be installed on machines like ventilators, blasts, separators or decanters in order to protect these machines in the application against inadmissible mechanical vibration. The unit monitor continuously the intensity of vibration and warn reliably during exceeding of, inside the unit, adjusted limit values.

4. Measurement principle

The sensor operates according to the piezoelectric principle and converts the mechanical vibrations into an electrical alternating voltage. The subsequent electronics convert the AC voltage signal into a DC voltage that corresponds to the measured vibration velocity. The sensitivity, i.e. the measuring range, can be easily selected inside the unit by means of switches. The measured range is adjusted by DIP-switches inside the unit.

The measured value is compared with two adjustable limiting values G1 and G2, which could be adjusted in range of 10% to 100% with two potentiometers inside the unit. At the analog output the limit values of G1 and G2 can be adjusted when setting of the DIP-switches corresponds to the prove position. If the measured values G2 exceed the critical limit, alarm relay K2 will be activated after e.g. 5 seconds delay time. If limit value G1 is exceeded for more than e.g. 10 seconds, alarm relay K1 will be activated. If measured value falls below the limit value, alarm will be cancelled *).

At the analog output is the measurement value proportional to the fitted measurement range available, by voting 0 to 20mA or 4 to 20mA.

The unit includes a self-test feature with them all electronic components inside the unit could be tested. Further more exist also the possibility, for testing purpose to supply one test signal in to the measurement electronic.

*) Additional supply with alarm memory. After the activation of the alarm relay K1 (or on customer request K2) the unit will remain in the alarm status until an external and manually reset will be activated. This feature is used in such cases, where the vibration control unit is mounted on unreviewable and difficult accessible places. Through this advanced memory function is every alarm registered. Because of variable mounting of one or more parallel connected reset buttons, it is possible to reset the alarm memory from any place or location.

The reset occurs by connection of the external reset contact (violet core) to +24V.

5. Grounding concept

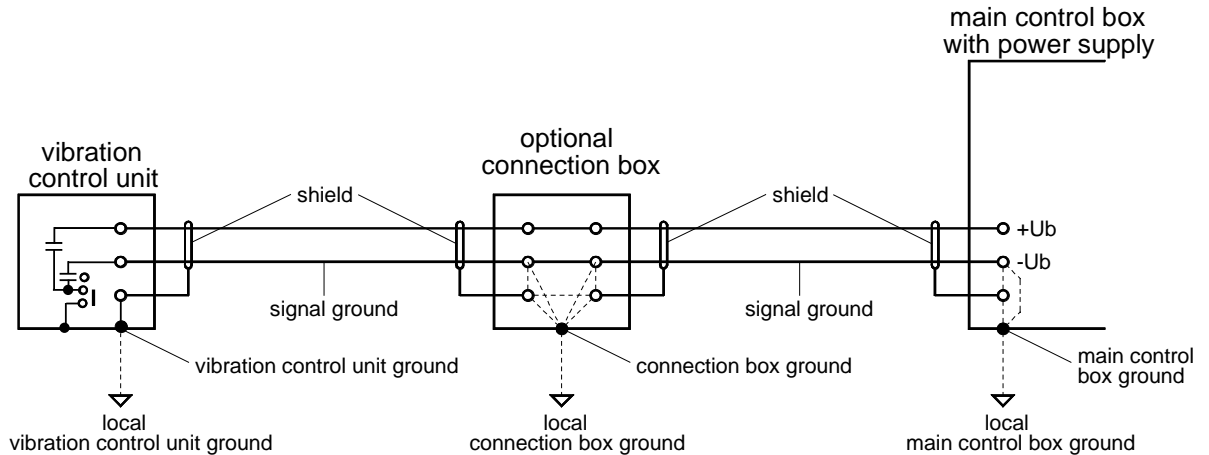

If an isolated mounting is not explicitly desired, it can usually be assumed, by screwing the components together, that the housings will accept the respective local machine ground potential.

Inside the ESW[®]-Compact_II unit, the shield is at housing potential by factory. The internal supply and the signal ground can remain separated from the shield or be connected to the case potential via coupling capacitors, depending on the customer's requirements.

In the Standard version of the ESW[®]-Compact_II, the supply lines are connected to the housing potential via capacitors.

In an optional terminal box, the cable shielding, the box ground and the signal ground can also be connected optionally and according to the local conditions and requirements.

In big facilities with considerable energy consumption and distances between the machines could such big potential difference be build up, that substantial balancing current on the ground network will occur. Dependent on intensity of such currents is arising of interference's or damaging of the unit the result!

Even at small spatial distances, potential steps can occur due to ambiguously defined transition points (paint) or moving parts (springs, moving suspensions).

Energetic high frequency interference energy could be added to the measurement signal-wire by inductivity or trough capacity that could change the real existing measurement value! In this way, for example parallel going elements could act as coupling-capacitor and winded up grounding cable could act like a cut off choke.

Memorize: Ground is not equal everywhere!

→ Check the situation → Plan the grounding concept → Select the facility / realization

6. Mounting of the vibration control unit

Attention: Whole mounting-, connecting- and adjustment-work should be done only from qualified personal!

Protect the ESW[®]-Compact_II definitely against drop, stroke and other mechanical shock!

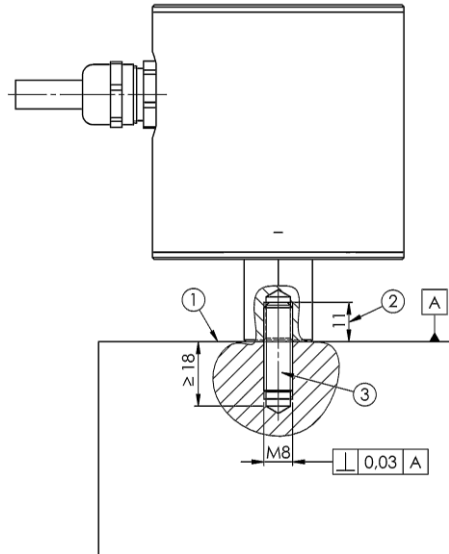

- ① mounting surface
- ② max. screw depth
- ③ secure grub screw M8x25 with loctite

The ESW[®]-Compact_II unit is fastened with means of a screw set AM 8x25 correspond to DIN 913 to the monitored machine.

Important

1. Measuring axis has to be coinciding with vibration excitation axis (see housing size page 14).
2. Take note of the label with instruction notes.
3. The surface has to be plain, clean and free of paint and rust.
4. The tap hole has to be perpendicular to the surface and free of metal-cuttings or other foreign material. Further more the tap hole and the screw have to be free of paint, rust, grease or other isolating components.
5. The grub screw has to be locked with liquid thread protection against unintended loosening.
6. The unit has to be fixed, tight on the surface.
7. The user has to fasten the connection cable near the cable insertion in a radius of app. 20cm. This attachment has to be done so that the cable is not dejected and damaged.
8. Please follow absolutely the advices for opening and closing the unit.

7. Opening and closing of the vibration control unit

Before opening the vibration control unit, switch the power supply off. For opening you will need a forehead key for two bore with size of 4mm.

After adjustment of the unit, please control the position of the DIP-switches. Before closing the unit the O-Ring must be examine. You have to insert a new O-Ring (62 x 2mm, NBR 70 – original spare part) if the old one is brittle, deformed, damaged or already a few month in use.

Please pay attention that thread and the interior room is oil and dirty free. Cleaning around and inside of the unit should only be done with clean and dry clothe.

8. Maintenance

The ESW[®]-Compact_II is maintenance free! Cleaning of the sight glass with aggressive scouring powder of any kind should be avoided.

If it is necessary in the future, after setting the unit into operation, to reset or check the sensor, the O-ring is to be replaced before mounting the cover.

The fuse F1 is soldered fixed and should exclusively be replaced by qualified personal. For replacement is a SMD-fuse, type OMF (63V,1A) required.

Tools for case cover opening: Adjustable forehead key for two bore nut size 4mm

Factory: H. Sartorius Nachf. GmbH & Co

phone +49 (0) 21 02 / 44 00 - 0

fax +49 (0) 21 02 / 44 00 - 24

9. Operating and setting instructions

The display and operating elements will be accessible after unscrewing the cover of the ESW[®] Compact_II unit.

Display elements

Operation

LD2	LED green	operation-voltage on
	LED yellow	Self-test "active"

Limit 1, e.g. pre contact

LD1	LED off	measured value < limit
	LED yellow	measured value > limit reponse delay running
	LED orange	relay K1 has switched measured value > limit
	LED red	relay K1 has switched measured value < limit drop-out delay time running

Limit 2, e.g. main contact

LD3	LED off	measured value < limit
	LED yellow	measured value > limit reponse delay running
	LED orange	relay K1 has switched measured value > limit
	LED red	relay K1 has switched measured value < limit drop-out delay time running

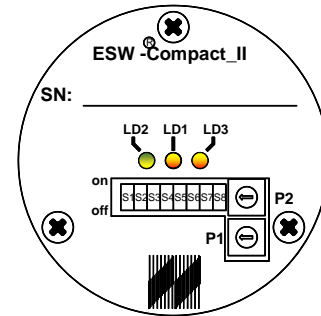

Operating elements

P1	Potentiometer for setting limiting value G1	10 to 100%
P2	Potentiometer for setting limiting value G2	10 to 100%
S1	Range 0 to 10mm/s	ON/OFF
S2	Range 0 to 20mm/s	ON/OFF
S3	Range 0 to 50mm/s	ON/OFF
S4	Analog output	0 to 20mA 4 to 20mA
S5	Analog output corresponds to measured value	ON/OFF
S6	Analog output corresponds to limiting value G1	ON/OFF
S7	Analog output corresponds to limiting value G2	ON/OFF
S8	Self test activated	ON/OFF

Setting instructions

After applying the voltage supply the LED LD2 must light up green. The LED's LD1 and LD3 should remain dark. The relays are switching in their normal position.

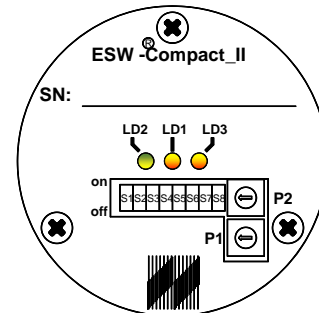

10. Measurement range switching

The unit has three measurement ranges, which can be selected by the switches S1, S2 and S3. For a proper operation of the unit, only one switch has to be in position "ON", the both other switches should remain in position "OFF".

Range	Switch Position		
	S1	S2	S3
10mm/s	ON	OFF	OFF
20mm/s	OFF	ON	OFF
50mm/s	OFF	OFF	ON

11. Analog output

As the output value will be submitted constant current, by voting 0 to 20mA or 4 to 20mA. The selection occurs by switching over of switch S4. An output current of 20mA meets the 100%-value of the selected measurement range. In the setting of 0 to 20mA is the valid relation 0.2mA per %, in the setting of 4 to 20mA is the valid relation 4mA + (0.16mA per %).

Output range	Switch position
0 to 20mA	S4 ON
4 to 20mA	S4 OFF

12. Analog output settings

The 0 to 20mA output can be used for displaying of several values on the analog output. With the standard setting the output current corresponds to the measured signal.

For example, an analog current value of 20mA corresponds to a measured vibration velocity that has reached 100% of the measuring range set.

Important By switching over the Dip switches, the analog output can be used for setting or reading of the limit values G1 and G2.

The output range 0 to 20mA is suitable for this purpose. For the limit value setting, a current of e.g. 20mA means that the switching threshold is at 100% of the set measuring range, 12mA would then correspond to 60%.

Output Variable	Switch Position		
	S5	S6	S7
Vibration velocity	ON	OFF	OFF
Limiting value G1	OFF	ON	OFF
Limiting value G2	OFF	OFF	ON

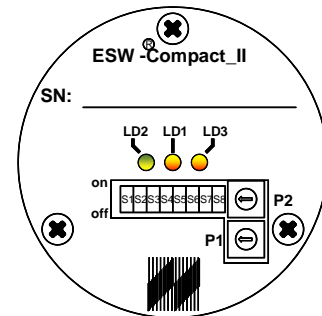

13. Adjustment of the limiting values

If the measuring signal exceeds certain limiting values, the ESW[®]-Compact_II shall react by switching potential-free relay contacts. These limit values can be set inside the unit by potentiometers. The limit values can be set between 10% and 100% of the selected measuring range.

The limit value G1 will be adjusted with potentiometer P1. Exceeded the value of G1 for example longer as 10s, then K1 is switched. The limit value G2 will be adjusted with potentiometer P2. If limit of G2 will be longer than 5s exceeded, then K2 is switched. Rest the measured value just from time to time over the limit value, so counts the activation delay time after each overstepping of the limit value once more.

When the analog output of the limiting value setting is switched over, the output current related to 20mA will correspond to the setting of the limiting value related to 100% of the measuring range. If, e.g. G1 has to be set to 15mm/s = 30% in the measuring range of 50mm/s, the output range will be first set to **0 to 20mA** via S4 and the output variable to limit value G1 via S5=OFF, S6=ON and S7=OFF. After that, a current output of 6mA (= 30% of 20mA) has to be adjusted by potentiometer P1. A current of 8.8mA (= 4mA + 30% of 16mA) should be set in the output range **4 to 20mA**. The difference between 4 and 20 is 16 ⇒ 30% of 16mA + 4mA = 8.8mA

After setting the limiting values, please pay attention that S5 will be brought to position "ON" and S6, S7 to position "OFF" to activate the function of the analog output as a measuring output.

14. Example to adjust the limit value

Example 1: Analog output 0 to 20mA (mean 0.2mA per %)

Adjust the limit value G1 to 22.5%, and the limit value G2 to 35%:

Measured range 20mm/s	S1	OFF
	S2	ON
	S3	OFF
Analog output 0 to 20mA	S4	ON
Balancing of the limit value G1 to 22.5%	S5	OFF
	S6	ON
	S7	OFF
Set the output current to 4,5mA via P1 (22.5% of 20mA is 4.5mA)		
Balancing of the limit value G2 to 35%	S5	OFF
	S6	OFF
	S7	ON
Set the output current to 7mA via P2 (35% of 20mA is 7mA)		
Measuring variable "vibration velocity"	S5	ON
	S6	OFF
	S7	OFF
Self test off	S8	OFF

Example 2: Analog output 4 to 20mA (mean 0.16mA per %)

Adjust the limit value G1 to 45%, and the limit value G2 to 60%:

Measured range 20mm/s	S1	OFF
	S2	ON
	S3	OFF
Analog output 4 to 20mA	S4	OFF
Balancing of the limit value G1 to 45%	S5	OFF
	S6	ON
	S7	OFF
Set the output current to 11.2mA via P1 (45% of 16mA is 7.2mA + 4mA)		
Balancing of the limit value G2 to 60%	S5	OFF
	S6	OFF
	S7	ON
Set the output current to 13.6mA via P2 (60% of 16mA is 9.6mA + 4mA)		
Measuring variable "vibration velocity"	S5	ON
	S6	OFF
	S7	OFF
Self test off	S8	OFF

15. Self test

A self-test circuit in the unit is integrated to check the ESW[®]-Compact_II for checking functionality. The self-test function could be activated by switches inside the unit. The LED LD2 changed light from green to yellow. The LED LD1 and LD3 must turn yellow. After expiration of fixed setting delay-time's K1 and K2 must switch and the LED's LD1 and LD3 must light up red. If the measurement range of 50mm/s has been selected, the analog output provides a current of more than 20mA. In the other measuring ranges the current must be over 25mA. During the self-test function is the whole electronic incorporated, so that it's possible to obtain a definite information about the function of the unit.

Function	Switch position
Self test on	S8 ON
Self test off	OFF

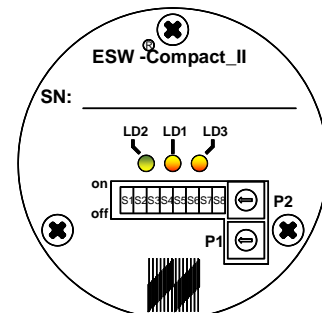

Upon execution of the self-test function, it's absolutely necessary to return the switch S8 to the position OFF in order to ensure the proper function of the ESW[®]-Compact_II. The yellow LED must darken and current has to return to his normal value. In case the yellow LED is lighting and a higher output current is flowing, without of activation of S8, than the electronic recognize a sensor defect and starts alarm, because the electronic is continuously monitoring the sensor.

16. Housing size (mm)

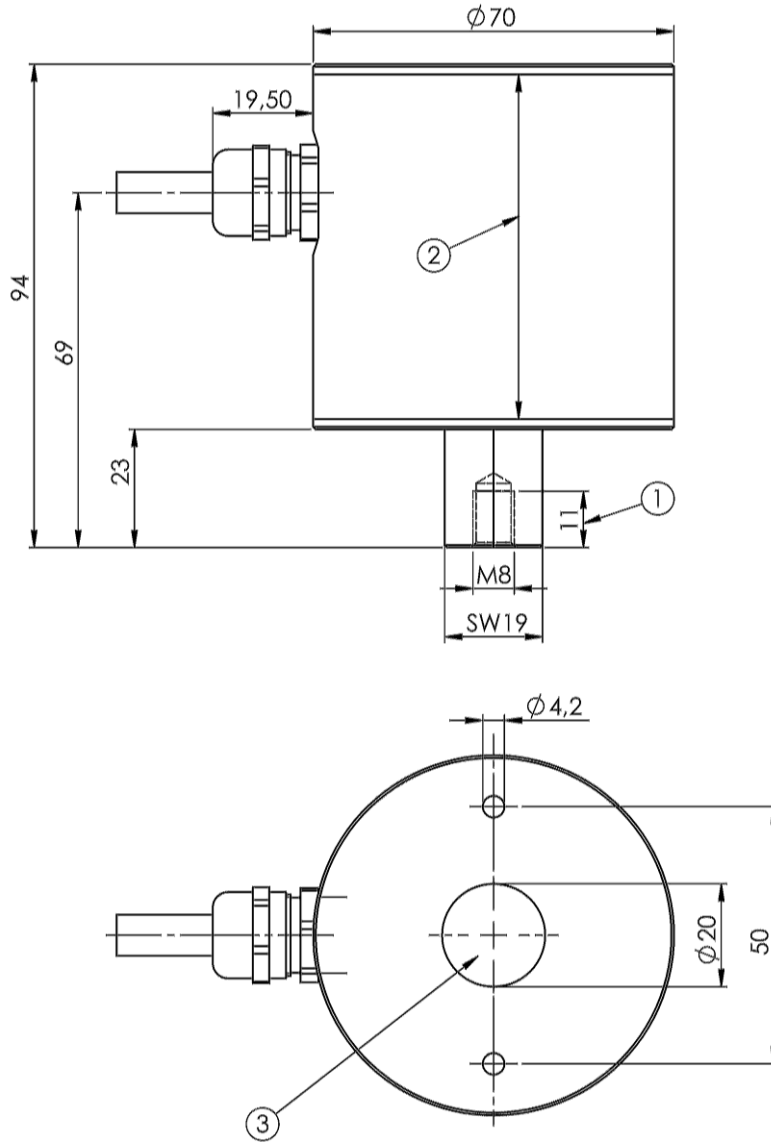

- ① max. useable depth of thread
- ② measuring axis
- ③ plexiglass window



Typ: ESW[®]Compact_II
S/N:

Wevelinghoven 38
D-41334 Nettetal
www.esw.eu

(hol600) 
0035

17. Cable connection draft

Version without external reset

ESW®-Compact_II

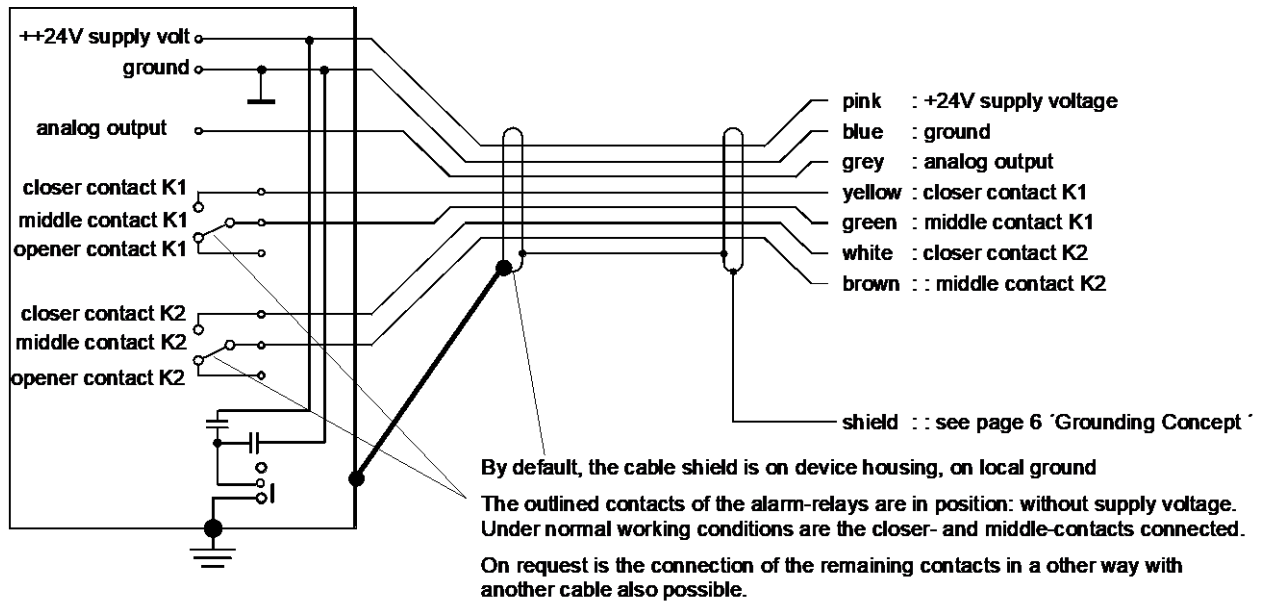

Version including external reset

ESW®-Compact_II

